

YOUR MOST TRUSTABLE HOIST FOR MORE THAN 10 YEARS

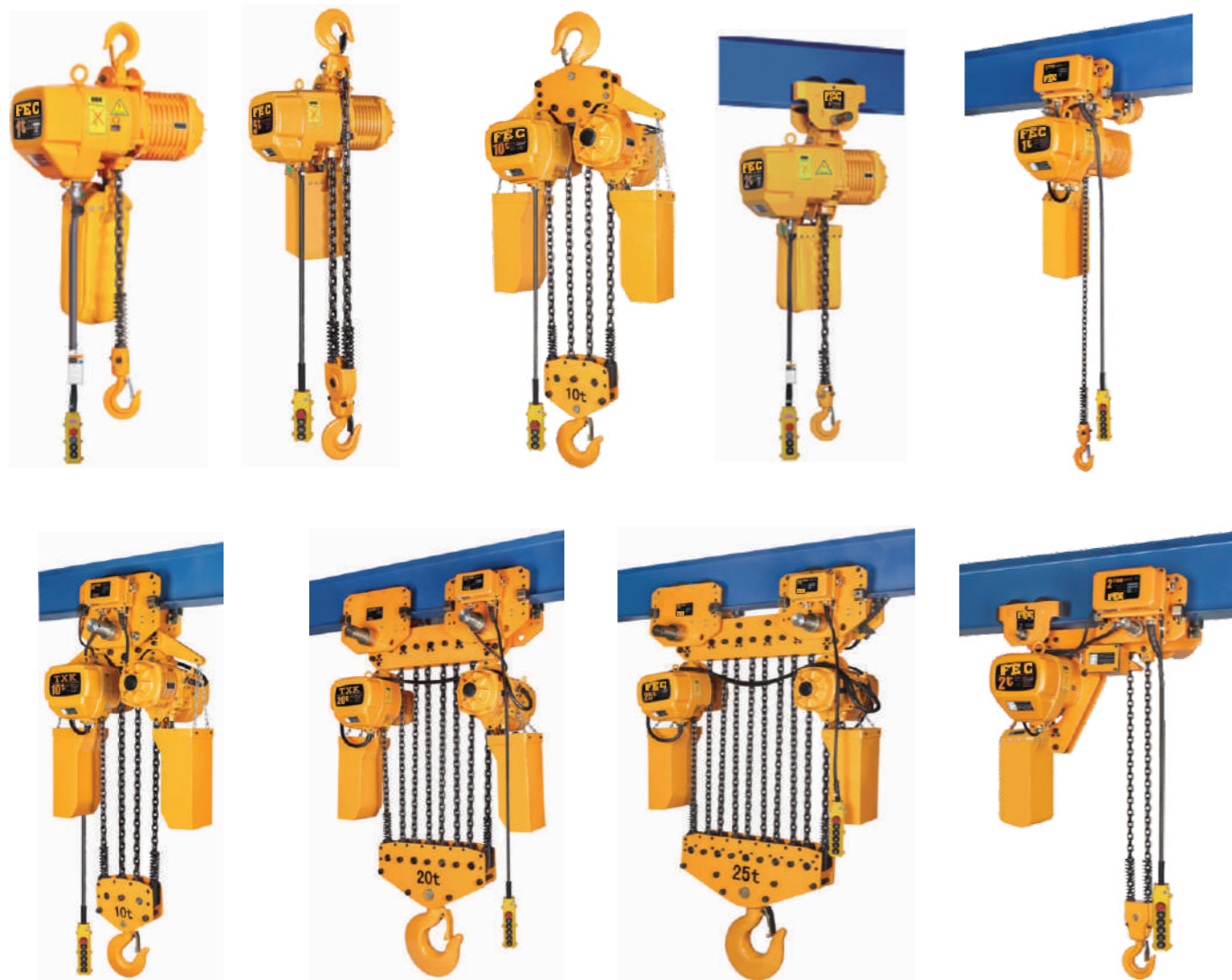

The **FEC** electric chain hoist **PRO** series has been well sold in more than 50 countries in last 10-years. It is equipped with mature technology, therefore can provide long-period stable operation which is very important for production efficiency. By great reputation from thousands customers in the world, **PRO** series would always be your most trustable and reliable choice of economic lifting solution.



Electric Trolley <<

The range of flange width is adjustable. Motor include disc type brakes. Side guide rollers are to promote the trolley motion smooth and minimize the wear of wheel and beam.

Heavy Duty Hoist Motor <<

Light aluminium alloy shell, light but hard. The cooling fin is specially designed to ensure quick heat dissipation with the rate up to 40% and continuous service.

Safe Brake System <<

Electric brake is designed for easy access and simple adjustment. It allows instant brake as soon as the electric power is cut off. Thus the braking safety while loading is guaranteed.

Upper and Lower Limit Switch <<

The limit switch will cut off the motor circuit and prevent the damage to hoist structure and load chain when over-lifting or over-lowering happens.

Inverse Phase Sequence Protecting Device <<

It's the special electrical installation of controlling the circuit not work in case of wiring error in the power supply.

Load Sheave / Reduced Vibration <<

Increasing the number of load sheave pockets helps relieve vibrations produced by revolving polygonal sheave on the hoist's body and load chain.

Load Chain <<

G80 FEC Ultra heat-treatable alloy steel chain, has a high resistance to wear and corrosion.

Hooks <<

Load hook is forged carbon steel hook with a heavy-duty hook latch. Thrust bearing in hook allows 360° rotation to prevent twisting of load chain. Top hook, for hook suspended hoist is rigid.

Chain Container <<

Canvas chain container is a standard fittings. Operation fabricated steel containers are available for long lift applications.

Push Button Control <<

Compact design to enable one-handed operation. Rated IP55 protection. Emergency stop button is included. Push button cable has strain relief to prevent cable damage.



ELECTRIC CHAIN HOIST 500Kg-10Ton



1. Three meters of lifting height and power supply cable as standard fittings.
2. Extending the load chain is prohibited with additional links.
3. Optional lifting length, push button cord and power supply cable besides standard is available on your request.
4. Canvas chain container is standard fittings. Steel chain containers are available if your lift is more than capacity of the standard container volume.
5. Emergency stop button on the push button switch, push it down, the motor circuit will be cut off.
6. Power voltage: 220V-690V, dual voltage are available. 50Hz and 60Hz are optional.
7. Control voltage: 24V, 36V, 48V are optional.
8. Wireless remote control can be assembled.

Hoist with Hook

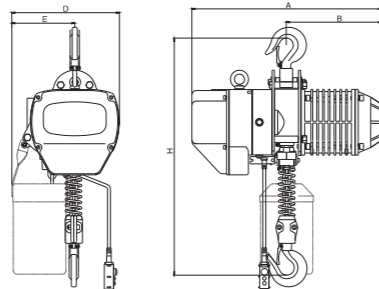

Hoist with Electric Trolley

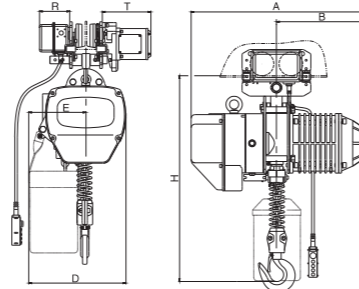

Single Speed

Technical Parameters

Model	SSDHL									
	0.5-01S	01-01S	1.5-01S	02-01S	02-02S	2.5-01S	03-01S	03-02S	03-03S	05-02
Capacity(t)	0.5t	1t	1.5t	2t		2.5t	3t			5t
Lifting Speed(m/min)	7.2	6.6	8.8	6.6	3.3	5.4	5.4	4.4	2.2	2.7
Motor Power(Kw)	0.8	1.5	3.0	3.0	1.5	3.0	3.0	3.0	1.5	3.0
Rotation Speed(r/min)	1440									
Insulation Grade	F									
Power Supply	3P 220V~690V									
Control Voltage	24V/36V/48V									
No. of Chain	1	1	1	1	2	1	1	2	3	2
Spec. of Load Chain	φ6.3	φ7.1	φ10.0	φ10.0	φ7.1	φ11.2	φ11.2	φ10.0	φ7.1	φ11.2
Net Weight(Kg)	47	61	108	115	73	115	122	131	85	151

Dual Speed

Technical Parameters

Model	SSDHL									
	0.5-01D	01-01D	1.5-01D	02-01D	02-02D	2.5-01D	03-01D	03-02D	03-03D	05-02D
Capacity(t)	0.5t	1t	1.5t	2t		2.5t	3t			5t
Lifting Speed(m/min)	7.2/2.4	6.9/2.3	9.0/3.0	6.9/2.3	3.3/1.1	5.4/1.8	5.4/1.8	4.5/1.5	2.4/0.8	2.7/0.9
Motor Power(Kw)	0.8/0.27	1.8/0.6	3.0/1.0	3.0/1.0	1.8/0.6	3.0/1.0	3.0/1.0	3.0/1.0	1.8/0.6	3.0/1.0
Rotation Speed(r/min)	2880/960									
Insulation Grade	F									
Power Supply	3P 220V~690V									
Control Voltage	24V/36V/48V									
No. of Chain	1	1	1	1	2	1	1	2	3	2
Spec. of Load Chain	φ6.3	φ7.1	φ10.0	φ10.0	φ7.1	φ11.2	φ11.2	φ10.0	φ7.1	φ11.2
Net Weight(Kg)	54	74	144	150	86	148	159	168	102	184

Nonstandard Power Supply Can Be Customized

Hoist with Hook

Size Specifications

Model	H	A	B	D	E
SSDHL 0.5-01S	530	460	230	288	178
SSDHL 0.5-01D	530	545	260	288	178
SSDHL 01-01S	650	520	260	300	176
SSDHL 01-01D	650	582	280	300	176
SSDHL 1.5-01S	800	615	295	430	265
SSDHL 1.5-01D	800	670	313	430	265
SSDHL 02-01S	800	615	295	430	265
SSDHL 02-01D	800	670	313	430	265
SSDHL 02-02S	835	520	260	300	236
SSDHL 02-02D	835	582	280	300	236
SSDHL 2.5-01S	845	615	295	430	265
SSDHL 2.5-01D	845	670	313	430	265
SSDHL 03-01S	845	615	295	430	265
SSDHL 03-01D	845	670	313	430	265
SSDHL 03-02S	950	615	295	430	320
SSDHL 03-02D	950	670	313	430	320
SSDHL 03-03S	950	520	260	350	205
SSDHL 03-03D	950	582	280	350	205
SSDHL 05-02S	1030	615	295	430	325
SSDHL 05-02D	1030	670	313	430	325

Hoist with Electric Trolley

Size Specifications

Model	H	A	B	D	E
SSDHL 0.5-01S	635	460	230	288	178
SSDHL 0.5-01D	650	545	260	288	178
SSDHL 01-01S	650	520	260	300	176
SSDHL 01-01D	650	582	280	300	176
SSDHL 1.5-01S	770	615	295	430	265
SSDHL 1.5-01D	770	670	313	430	265
SSDHL 02-01S	770	615	295	430	265
SSDHL 02-01D	770	670	313	430	265
SSDHL 02-02S	815	520	260	300	236
SSDHL 02-02D	815	582	280	300	236
SSDHL 2.5-01S	830	615	295	430	265
SSDHL 2.5-01D	830	670	313	430	265
SSDHL 03-01S	830	615	295	430	265
SSDHL 03-01D	830	670	313	430	265
SSDHL 03-02S	930	615	295	430	320
SSDHL 03-02D	930	670	313	430	320
SSDHL 03-03S	940	520	260	350	205
SSDHL 03-03D	940	582	280	350	205
SSDHL 05-02S	1015	615	295	430	325
SSDHL 05-02D	1015	670	313	430	325

ELECTRIC CHAIN HOIST 7.5Ton



Technical Parameters

Model	SSDHL	
	7.5-03S	7.5-03D
Capacity(t)	7.5t	
Lifting Speed(m/min)	1.8	1.8/0.6
Motor Power(Kw)	3.0	3.0/1.0
Rotation Speed(r/min)	1440	2880/960
Insulation Grade	F	
Power Supply	3P 220V~690V	
Control Voltage	24V/36V/48V	
No. of Chain	3	3
Spec. of Load Chain	φ11.2	
Net Weight(Kg)	176	215

Size Specifications

Model	H	A	B	D	E
SSDHL7.5-03S	1200	615	295	505	320
SSDHL7.5-03D	1200	670	313	505	320

Hoist with Hook

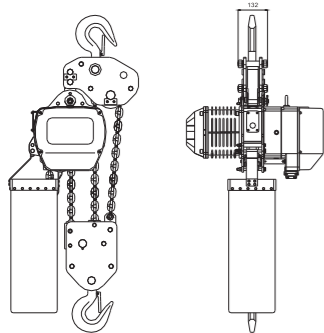

Hoist with Electric Trolley

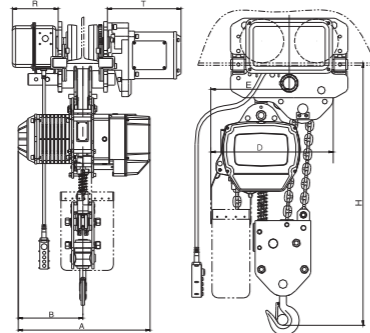

ELECTRIC CHAIN HOIST 10Ton



Technical Parameters

Model	SSDHL	
	10-04S	10-04D
Capacity(t)	10t	
Lifting Speed(m/min)	2.7	2.7/0.9
Motor Power(Kw)	3.0x2	3.0x2/1.0x2
Rotation Speed(r/min)	1440	2880/960
Insulation Grade	F	
Power Supply	3P 220V~690V	
Control Voltage	24V/36V/48V	
No. of Chain	4	4
Spec. of Load Chain	φ11.2	
Net Weight(Kg)	300	380

Size Specifications

Model	H	A	B	D	E
SSDHL10-04S	1400	630	315	890	445
SSDHL10-04D	1400	670	388	890	445
SSDHL10-04S	1190	630	315	890	445
SSDHL10-04D	1190	670	388	890	445

Hoist with Hook

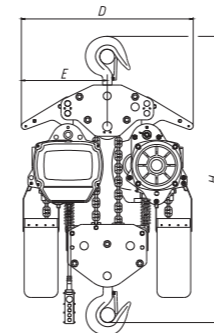

Hoist with Electric Trolley

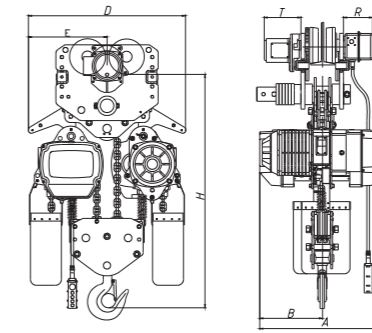

ELECTRIC CHAIN HOIST 15Ton-25Ton

Hoist with Electric Trolley

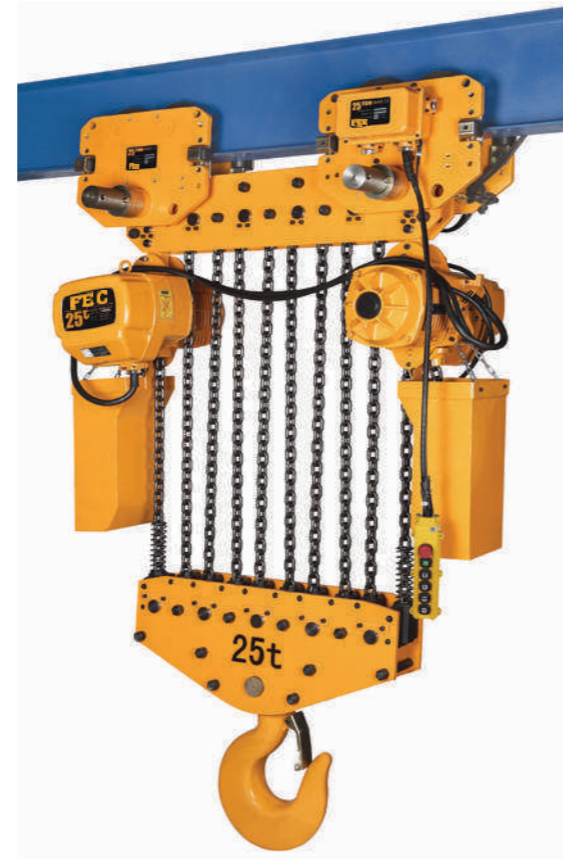
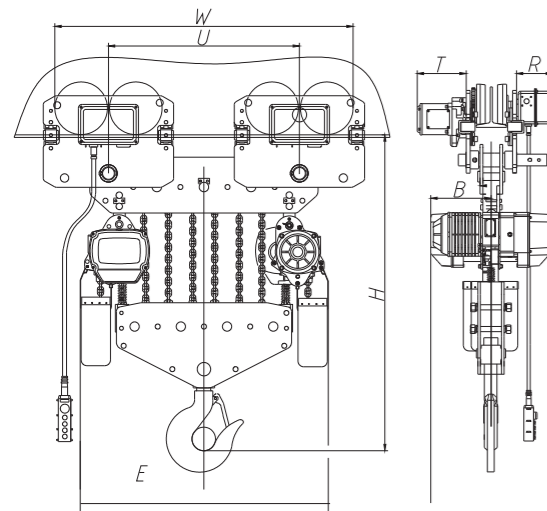

ELECTRIC CHAIN HOIST 30Ton-50Ton

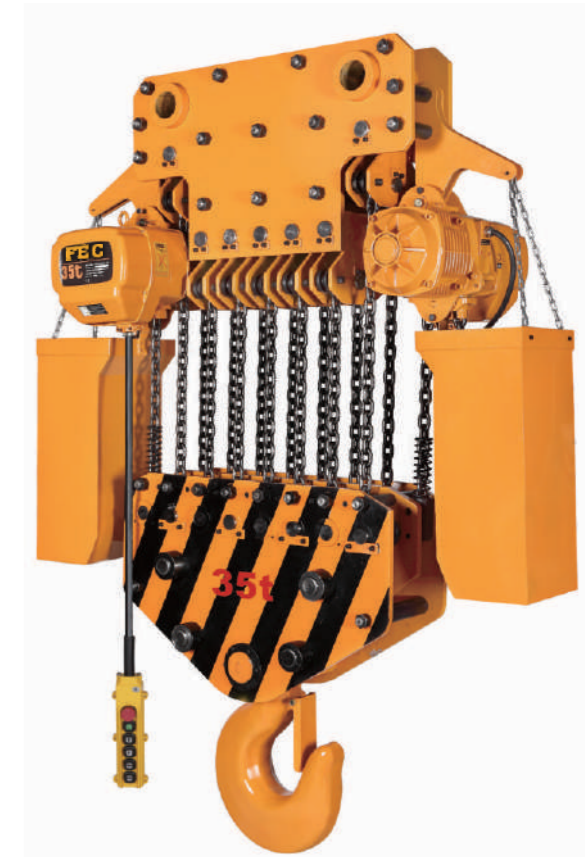
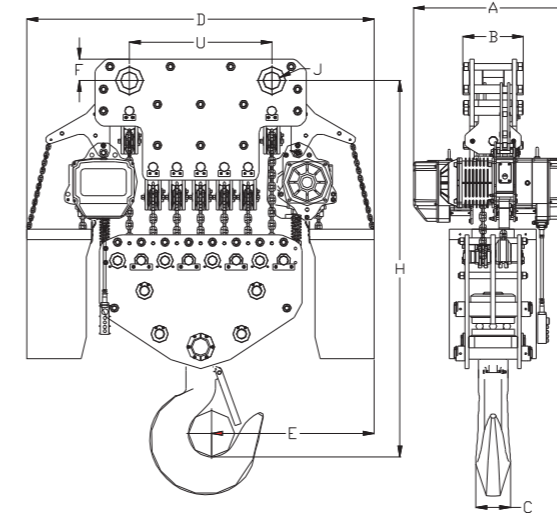

Technical Parameters

Model	Capacity (t)	Lifting Speed (m/min)	Motor Power (kw)	Rotation Speed (r/min)	Insulation Grade	Power Supply	Control Voltage	No. of Chain	Spec. of Load Chain	Net Weight (kg)	I Beam (mm)
SSDHL15-06S	15	1.8	3.0*2	1440	F	3P/220V-390V	24V/36V/48V	6	Φ11.2	382	150-220
SSDHL15-06D	15	1.8/0.6	3.0*2/1.0*2	2880/960				6	Φ11.2	455	150-220
SSDHL20-08S	20	1.4	3.0*2	1440				8	Φ11.2	482	150-220
SSDHL20-08D	20	1.5/0.5	3.0*2/1.0*2	2880/960				8	Φ11.2	545	150-220
SSDHL25-10S	25	1.1	3.0*2	1440				10	Φ11.2	503	150-220
SSDHL25-10D	25	1.2/0.4	3.0*2/1.0*2	2880/960				10	Φ11.2	579	150-220

Size Specifications

Model	H	A	B	D	E	W	U	R	T
SSDHL15-06S	1310	630	315	1070	535	926	560	142	231
SSDHL15-06D	1310	670	388	1070	535	926	560	142	231
SSDHL20-08S	1470	630	315	1260	630	1106	740	142	231
SSDHL20-08D	1470	670	388	1260	630	1106	740	142	231
SSDHL25-10S	1580	630	315	1460	725	1280	930	142	231
SSDHL25-10D	1580	670	388	1460	725	1280	930	142	231

Technical Parameters

Model	Capacity(t)	Lifting Speed (m/min)	Motor Power (kw)	Rotation Speed (r/min)	Insulation Grade	Power Supply	Control Voltage	No. of Chain	Spec. of Load Chain
SSDHL30-12S	30	0.9	3.0*2	1440	F	3P 220V-690V	24V/36V/48V	12	Φ11.2
SSDHL30-12D	30	0.9/0.3	3.0*2/1.0*2	2880/960				12	Φ11.2
SSDHL35-14S	35	0.75	3.0*2	1440				14	Φ11.2
SSDHL35-14D	35	0.75/0.25	3.0*2/1.0*2	2880/960				14	Φ11.2
SSDHL50-20S	50	0.55	3.0*2	1440				20	Φ11.2
SSDHL50-20D	50	0.6/0.2	3.0*2/1.0*2	2880/960				20	Φ11.2

Size Specifications

Model	A	B	C	D	E	F	H	J	U
SSDHL30-12S	630	88	95	1260	630	115	1350	70	1020
SSDHL30-12D	670	88	95	1260	630	115	1350	70	1020
SSDHL35-14S	630	280	160	1610	755	100	1745	80	660
SSDHL35-14D	670	280	160	1610	755	100	1745	80	660
SSDHL50-20S	630	280	160	1815	855	160	1965	95	760
SSDHL50-20D	670	280	160	1815	855	160	1965	95	760

LOW HEADROOM HOIST 500Kg-10Ton

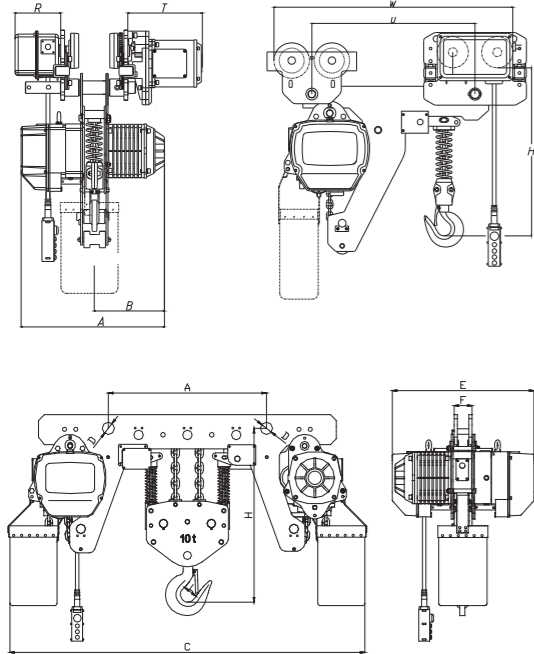

TWIN HOOK HOIST 500Kg-10Ton

The product consist of single motor and double hooks, ensuring the hooks lift vertically and stably, this type is used for the objects with two lifting points and the goods that need balances when lifting.

Hoist with Electric Trolley

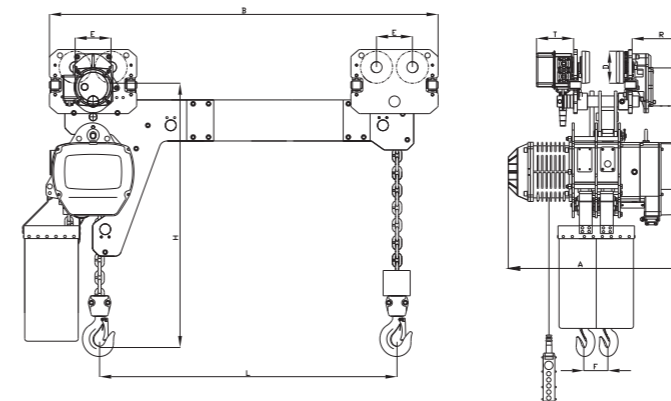

Technical Parameters

Model	SSDHL								
	0.5-01L	01-01L	02-01L	02-02L	03-01L	03-02L	05-02L	7.5-03L	10-04L
Capacity(ton)	0.5t	1t	2t	2t	3t	3t	5t	7.5t	10t
Lifting Speed(m/min)	7.2	6.6	6.6	3.3	5.4	4.4	2.7	1.8	2.7
Motor Power(Kw)	0.8	1.5	3.0	1.5	3.0	3.0	3.0	3.0	3.0
Rotation Speed(r/min)	1440								
Insulation Grade	F								
Power Supply	3P,220V-690V,50Hz/60Hz								
Control Voltage	24V/36V/48V								
No.of Chain	1	1	1	2	1	2	2	3	4
Spec.of Load Chain(Φ)	6.3	7.1	10.0	7.1	11.2	10.0	11.2	11.2	11.2

Size Specifications

Model	H	A	B	W	U
SSDHL0.5-01L	440	460	230	585	400
SSDHL01-01L	480	520	260	630	445
SSDHL02-01L	570	615	295	720	505
SSDHL02-02L	535	520	260	665	445
SSDHL03-01L	640	615	295	775	526
SSDHL03-02L	685	615	295	750	503
SSDHL05-02L	740	615	295	825	541
SSDHL7.5-03L	890	615	295	1020	730
SSDHL10-04L	850	615	295	996	700

Technical Parameters

Model	Capacity (Ton)	Lifting Speed (m/min)	Motor Power (kw)	Rotation Speed (r/min)	Insulation Grade	Power Supply	Control Voltage	NO of Load Chain	Spec.of Load Chain
SSDHL0.25+0.25t	0.5T	7.2	0.8	1400	F	3P/220V-690V/50Hz	24V/36V/48V	2 x 1	ø6.3
SSDHL0.5+0.5t	1T	6.6	1.5	1400	F	3P/220V-690V/50Hz	24V/36V/48V	2 x 1	ø7.1
SSDHL1+1t	2T	6.6	3.0	1400	F	3P/220V-690V/50Hz	24V/36V/48V	2 x 1	ø10.0
SSDHL1.5+1.5t	3T	5.4	3.0	1400	F	3P/220V-690V/50Hz	24V/36V/48V	2 x 1	ø10.0
SSDHL2.5+2.5t	5T	2.7	3.0	1400	F	3P/220V-690V/50Hz	24V/36V/48V	2 x 2	ø11.2

Size Specifications

Model	H	A	B	D	E	R	T	F
SSDHL0.25+0.25t	665	530	L+320	95	111	230	145	62
SSDHL0.5+0.5t	675	600	L+320	95	111	230	145	68
SSDHL1+1t	800	705	L+330	110	127	230	145	90
SSDHL1.5+1.5t	840	705	L+340	125	140	230	145	90
SSDHL2.5+2.5t	1100	705	L+500	140	156	230	145	90